

**IQPC - 3rd International Congress on
ADVANCED BATTERY TECHNOLOGY – 22 - 24.06.2010**

**Framework conditions for the use,
the safe transport and the recycling
of large Lithium batteries within the
development of the electric mobility**

Eckhard Fahlbusch
Chairman Environmental Committee

Main Topics

- **Essential parameters which depend on each other or affect each other**
 - **Variety of technical solutions within a fair competition**
 - **Standardization of Lithium battery technology**
 - **Adaption of transport regulations as well as a worldwide distribution and return of large Lithium batteries**
 - **The due development of sufficient recycling capacities**
-
-

Essential parameters

- Unexpected acceleration in regard to development of global electric mobility.
 - Caused by parameters which depend on each other or affect each other.
 - **The global competition among competitive technologies will allow their coexistence for a long period of time and will improve the respective quality even for the benefit of climate protection.**
-
-

Essential parameters

- Climate changes and its causes and impacts
 - Climate protection targets and programs (national/global)
 - Global competition in the automobile, supplier and battery industry
 - Competitive technologies (e.g. electric motor against combustion engine or traction battery against fuel cell and hydrogen engine)
 - New technologies has to stand up total ecological considerations
 - Consumer inducement and consumer behaviour
 - Urban development
-
-

Climate changes and its causes and impacts

- Besides the natural caused climate changes overall the emissions caused by human beings (principally CO₂) are responsible for the increasing global warming.
 - Meanwhile this result is not any more disputed.
 - The impact of global warming has further intensified respectively strengthened with increasing tendency.
 - **The further growing world population and the increasing industrialization as well as the urban development are forcing us to act also in the area of individual traffic.**
-

Climate protection targets and programs

- The noticeable impacts of global warming will lead to determination of political targets because of social and economical reasons.
 - The moderate results of the UN climate protection agreement of Copenhagen in December 2009 will not be the last step.
 - You have to take into consideration that **the future climate protection targets can only be achieved by use of new technical solutions.**
 - The funding of investments in new technologies is therefore primary crucial.
 - **The US government will fund 150 billion US dollar within the next 10 years for new technologies.**
-

Global competition in the automobile, supplier and battery industry

- BYD – Chinese car and battery manufacturer, goal >> 500,000 electric vehicles until 2012.
 - BMW is cooperating among other with SB Limotive a joint venture of Bosch and Samsung.
 - Daimler is working with JCS and has a cooperation with Evonik together with the battery manufacturers German Accumotive and Li-Tec.
-
-

Global competition in the automobile, supplier and battery industry

- VW and Sanyo (in future existing under the umbrella of Panasonic where Toyota is involved) would like to commission a lithium battery site in Germany in 2012.
 - VW is further cooperating with Varta Microbattery in regards to developing Lithium batteries with the objective of performance increase and cost reduction.
 - The advanced electric vehicle development of Renault/Nissan is also provided from Japan by NEC.
 - Currently Toyota is still concentrating on NiMH batteries and is waiting in regards to the further development of Lithium batteries.
-

Global competition in the automobile, supplier and battery industry

- Tesla and Johnson Controls are currently building Lithium battery sites in the USA funded by the US government (**50 % of the investment**).
 - Tesla is planning a 50 k€ electric vehicle with Lithium batteries.
 - Even General Motors, Ford and Chrysler are intensifying their activities especially in the area of Plug-In-Hybrid vehicles (also range extender).
-
-

Global competition in the automobile, supplier and battery industry

- Taking into consideration among these activities that e.g. **in Germany 70 % of all rides are below 17 km or 80 % below 25 km** you can reduce 80 % of the CO2 emissions caused by traffic with the use of a Plug-In-Hybrid vehicle with a range of 50 to 100 km (round trip).
 - Assumed that the charging **current is green**.
 - A reasonable supplement are full electric vehicles that can be used as **second car in conurbations**. The battery technology for these two vehicle models is available on short and medium term even in terms of costs.
-

Global competition in the automobile, supplier and battery industry

- Reflecting this scenario you need to pose the question whether the usual vehicle as **pure electric vehicle (EV) with a range of 500 km** and more will have a chance respectively is reasonable when considering the costs.
 - In this case a **niche market** can be developed e.g. **for EV's** in the premium price segment, public fleet vehicles or even in the taxi business.
-

Competitive technologies

- E.g. electric motor against combustion engine or traction battery against fuel cell and hydrogen engine)
 - This rivalry will further intensify the competition and will likely improve the entire technologies among environmental aspects.
 - We can expect a permanent optimising mixture of different drive technologies whose use can lead to a remarkable CO₂ reduction.
 - From my point of view the competition among these technologies is – supported by an appropriate government aid – considerably more effective than any other restrictive interference by legislation.
-
-

New technological solutions has to stand up total ecological considerations

- In short and medium term the optimization of the Lead battery and the combustion engine can lead e.g. in the VW Golf category to a **2-3 l consumption per 100 km.**
 - Reflecting ecological considerations the **hybrid or electric vehicle is only the winner when using energy out of renewable resources** like sun, wind and water for charging of the traction battery.
-

New technological solutions has to stand up total ecological considerations

- You need to take into account that the additional current demand is relatively small. **For charging 1 million electric vehicles you need less than 1 % of the entire current consumption.**
 - It is assumed that the electric mobility and the energy generation of renewable resources will be developed in parallel.
-
-

Consumer inducement and consumer behaviour

The **buying incentives** for hybrid or electric vehicles

- in China (up to 6,600 €),
- in Japan (up to 15,000 €),
- in France (up to 5,000 € and
- in the USA (up to 7,500 \$)

per vehicle will also force the German government to act.

From 2012/2013 we have to expect a comparable buying incentive in Germany –
if the German car manufacturers are prepared for the mass market.

Consumer inducement and consumer behaviour

In corresponding financially aided regions this would lead in short and medium term to a purchase of Plug-In-Hybrid vehicles (with a range of 50 to 100 km**) and small full electric vehicles without considerably extra costs. The further increasing ecological awareness of the consumer can accelerate the growth in this area considerably.**

Consumer inducement and consumer behaviour

- Even with decreasing battery costs a battery change to the current SLI Lead battery is difficult to place to the private consumer.
 - This means that the **traction battery needs to have the same life cycle as the vehicle**. Furthermore it is to clarify who will be in charge of which guarantee for the traction battery.
 - Besides the long-life cycle and reliability of Lithium batteries overall the **safety of Lithium batteries is a crucial criteria** in this ambitious and sensitive application area.
-
-

Urbanization in Progress

Cities with more than 5 million inhabitants

1955 11

1995 35

2015 60

City Restrictions and Eco Cities will push the e-mobility.

Variety of technical solutions within a fair competition

- For 2020 an environmental market of 3 trillion € is predicted.
 - Through this the environmental technology will become increasingly the leading industry.
 - **Example:** In 2009 worldwide 55 Mio new vehicles were placed on the global market. **2050 it should be 200 Mio new vehicles per year.**
 - The importance of batteries as energy storage will increase significantly worldwide.
 - Hence the battery manufacturers and its customers and suppliers will have great opportunities and challenges **but also potential risks and losses through the competition for market.**
-

Variety of technical solutions within a fair competition

Current revision of the End of Life Vehicles Directive - Exemption for Lead in Batteries -

- The Oeko Institute Freiburg recommends to fix a „review date“ of 5 years (without an end date or “expiry date” or phasing-out scenario).
 - Roland Berger and the German voice of industry - BDI emphasize the necessity of the Lead-acid battery also in the automotive future.
 - Joint Industry Meeting with the EU Commission on 14 June 2010 was successful.
 - A political decision in this direction means – **no political damage of the Lead-based battery technology.**
-

Variety of technical solutions within a fair competition

All in all a permanent optimising mixture of different traction and battery technologies can be expected that can lead to a considerably CO2 reduction. That means the **competition among**

- e.g. electric engine against combustion engine or
- traction battery against fuel cell respectively hydrogen engine or
- **Lead battery against Lithium respectively NiMH batteries**

will allow their coexistence for a long period of time (probably several decades) and will improve the respective quality. This is good for all involved persons also for climate protection.

Standardization of Lithium battery technology

- International standards **also for safe transportation and application** are in the pipeline.
 - UN Manual of Tests and Criteria – sub-section 38.3
 - Large Lithium batteries are classified with a gross mass of **more than 12 kg**
 - This mass is very important to fulfil the test requirements
 - UN Working Group is preparing an appropriate amendment of sub-section 38.3 for large Lithium batteries
-

Transport of large Lithium batteries

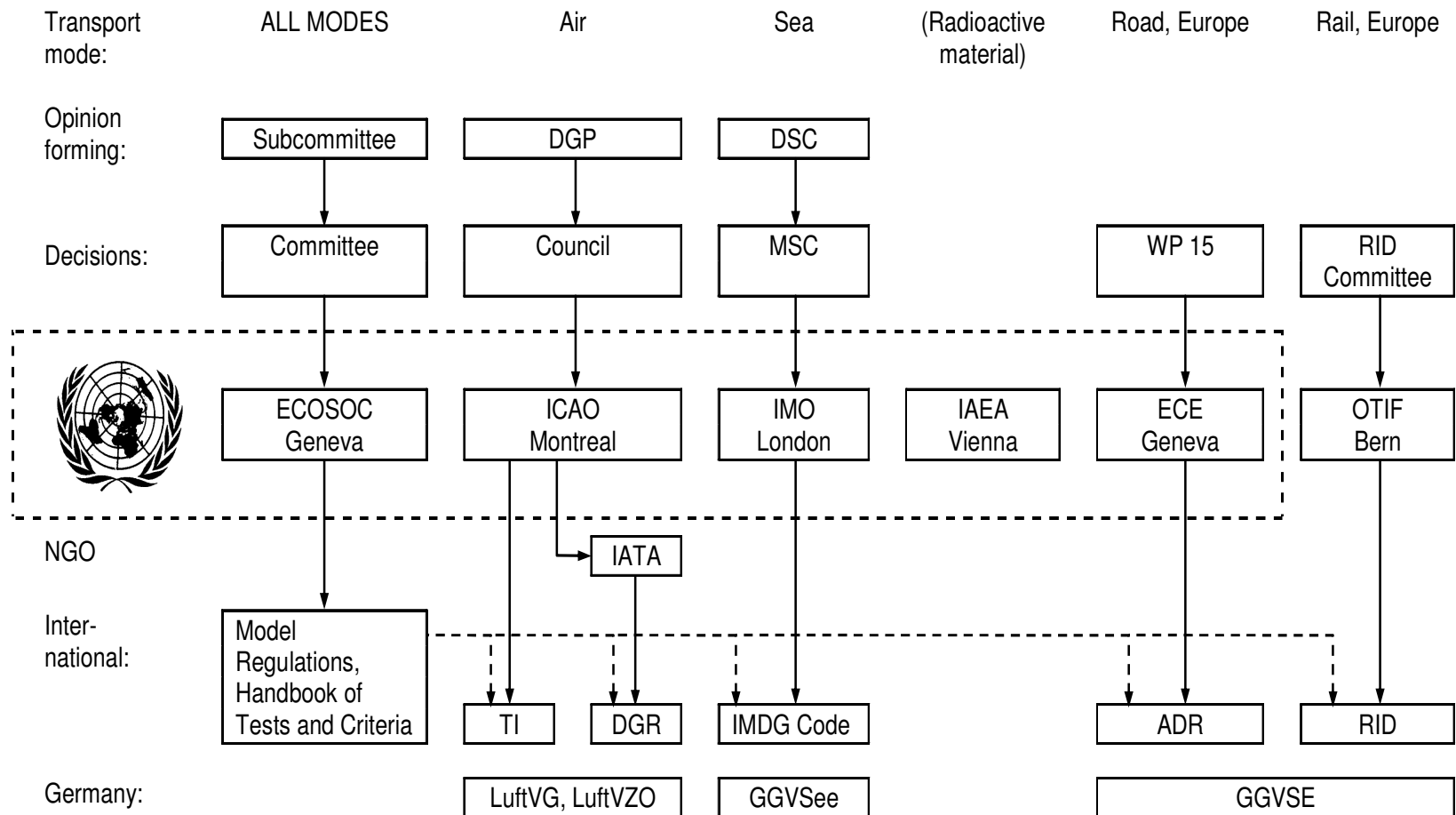

Transport of large Lithium batteries

- Required amendment of the Dangerous Goods Regulations for large Lithium batteries e.g. regarding hybrid and electric vehicles as well as energy storage from energy generation from renewable resources like sun, wind and water.
 - **Cancellation of the weight restrictions of 35 kg is mandatory.**
 - **An intense and convincing lobbying of the national and international automobile and battery industry is urgently needed.**
-

Transport of large Lithium batteries

- The achievement of the necessary and prompt amendments of the ICAO I.T. is not something that can be taken for granted.
 - U.S. DOT is very sensitive since the transportation ban for Lithium primary portable batteries in U.S. air traffic from 2003 and because of the **worldwide recall activities of equipment with lithium batteries**.
 - **DOT** has to be convinced regarding a safe and reliable transportation of the substantially larger Lithium batteries in the E-mobility area.
 - The same applies to **IFALPA**. It is unlikely to gain a majority against these two institutions under the roof of ICAO.
-
-

Transport of large Lithium batteries

- Thus, it is indispensable that the industry will even more convince the decision makers in the transportation committees worldwide - within the framework of a confident cooperation
 - that the application of Lithium batteries is demonstrably safe and
 - that Lithium batteries as energy storage will become extremely important among others for the automotive future and for energy storage from renewable resources and
 - a worldwide and safe distribution of these batteries has to be realized.
-

Transport of large Lithium batteries

- At the same time the government of the essential countries (especially USA, China, Japan, France, Italy, UK and Germany) has to support their respective member in the ICAO Dangerous Goods Panel (DGP).
 - Namely with the hint that an appropriate amendment of the ICAO I.T. for a worldwide distribution of large Lithium batteries is urgently needed and will be strongly supported by the governments.
 - Only by this new technologies – like the large Lithium batteries – can face a fair global competition – even in order to reduce CO2 emissions.
 - The VDA and the ZVEI`s battery association together will further push the governance activities in cooperation with the Luftfahrtbundesamt.
-
-

Transport of large Lithium batteries

- Need for action lies especially in air traffic - **cancellation of the weight restrictions of 35 kg.**
 - The ICAO are currently negatively influenced by unprofessional, incorrect and unreal reports and by inaccurate technical interpretations.
 - This results in an **unwillingness** to accept proposals for developing the ICAO T.I. for Lithium batteries, e.g. **to cancel the restriction of 35 kg.**
 - For this reason it is intended to synchronize the ICAO working group meeting with the „international strategy conference for electric mobility“ in May 2011 in Berlin—in cooperation with industry and politics **as confidence building measure.**
-

Transport of **used or spent large Lithium batteries**

- Appropriate Transport Regulations are necessary for service and maintenance as well as for the recycling of large Lithium batteries.
 - Mainly we will have Lithium batteries in an undamaged condition but also **damaged batteries** have to be transported.
 - For this reason Germany sent a proposal to the UN for decision **in strong coordination with the battery and car manufacturers.**
 - Appropriate solutions will be determined for **rail, road and sea traffic.**
-

Development of sufficient recycling capacities

- The recycling of large Lithium batteries is mandatory due to the **prohibition of the disposal in landfills or by incineration** according to Article 14 of the Battery Directive
 - For this reason we have to build up appropriate **collection schemes as well as recycling plants and capacities** in compliance with the market development towards the expected mass market.
 - **Recycling Efficiency of 50 %** according to Article 12 (6) (a) of the Battery Directive.
-

This is not our lobbying strategy

